

Anlage zu Anfrage/  
Bestellung

Referenz: \_\_\_\_\_

Kontakt: \_\_\_\_\_

## ANPASSUNG AN FAHRKORB / ADAPTERPLATTEN

**Aussengehäuse**  
(ohne Änderung)

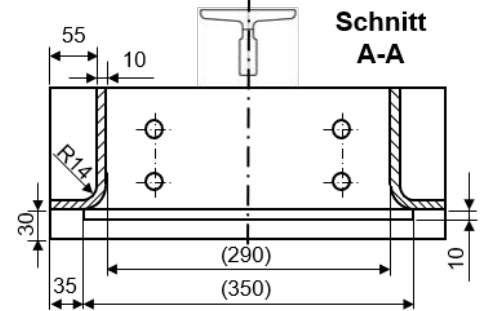
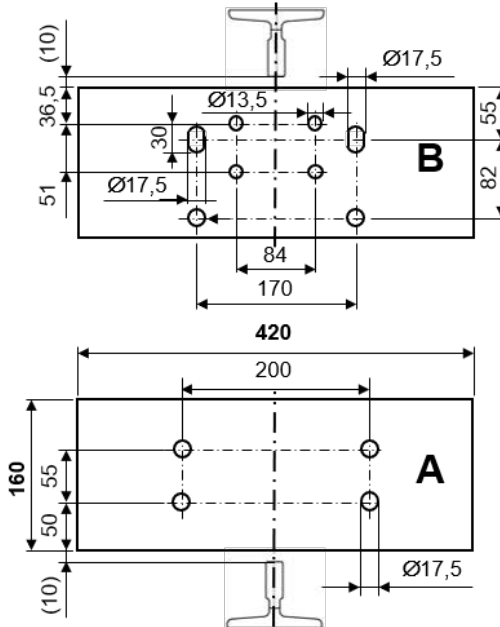
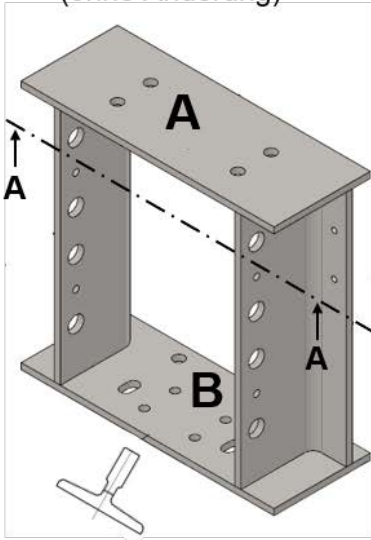

50.100.225 **Verstärktes Gehäuse:**

245 mm hoch

107.060.131 **Tandemgehäuse:**

415 mm hoch

**Gilt nicht für den Standardanbau des einfachen Gehäuses (107.060.046/047)**

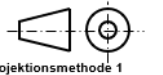







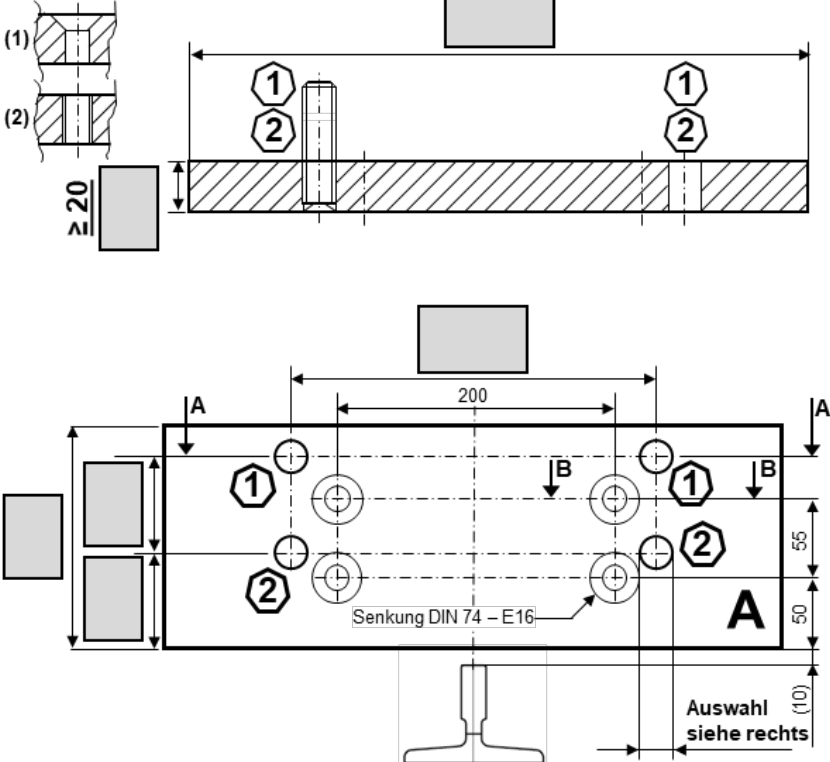

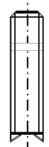





Projektionsmethode 1

Schnitt B-B

Schnitt A-A



|   |                                |   |   |
|---|--------------------------------|---|---|
|  | Steinbolzen<br>eingeschweißt   |  |  |
|  | Langloch                       |  |  |
|  | Rundloch                       |  |  |
|  | Gewinde                        |  |  |
|  | Zyl.-schraube<br>mit Innen-6KT |  |  |

Befestigung der Platte am  
FV-Gehäuse mit  
**4 x M16 Senkschrauben**  
Schnitt B-B (1)

Platte am FV-Gehäuse  
**angeschweißt**

Befestigung FV-Gehäuse an  
der Platte mit  
**4 x M16 6KT-Schrauben**  
Schnitt B-B (2)